

METTLER TOLEDO APPLICATION NOTE

pH And ORP Control Used In Cyanide Destruction

BACKGROUND

Electroplating processes generate waste materials in the form of alkaline, rare earth metals, and other heavy metals such as iron, nickel, zinc, cadmium, copper, silver, and gold. The wastes often contain cyanide, a deadly poison. Federal and State regulatory agencies require that cyanide discharge be below 0.5 ppm, and further tightening may be forthcoming. Therefore, the best policy is to destroy the cyanide totally before discharging the waste.

THE PROCESS

One of the most effective means to treat waste materials from electroplating processes is to destroy the cyanide with chlorine. This process is accomplished in two stages:

1. Cyanide is oxidized to cyanate, using pH and ORP control.
2. Cyanate is oxidized to nitrogen and carbon dioxide, harmless gases that can be safely discharged into the environment. This stage also uses pH and ORP control.

Oxidation of Cyanide to Cyanate

In the first reaction tank, the pH of the waste is measured and liquid caustic (NaOH at 50% strength) is automatically injected to raise the pH to 9 or higher.

The oxidation-reduction potential (ORP) of the waste is measured, and chlorine gas (Cl₂) is automatically injected to raise the ORP to 400 mV or higher.

The following reaction occurs, taking from 5 to 10 minutes:

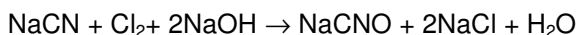

Destruction of Cyanate to Nitrogen and Carbon Dioxide

In the second reaction tank, the pH of the waste is measured and acid is injected to lower the pH to between 7 and 8. This process takes two to five minutes. In the third reaction tank, the ORP of the waste is measured and chlorine gas (Cl₂) is automatically injected to raise the ORP to 600 mV or higher. Meanwhile the pH controller maintains the set point to pH 7 to 8, correcting for any acidity created by the addition of the chlorine gas.

The following reaction occurs, taking 10 to 15 minutes:



The cyanide is eventually converted to harmless materials by the above reaction and the waste can be discharged. (Figure 1)

INSTRUMENTATION

pH and ORP control throughout is achieved with the Model 2100 pH/ORP Analyzer. The recommended sensor for pH and ORP measurement is the Xerolyt[®] electrode. For cyanide applications, the ORP electrode typically uses the material of gold for the measuring electrode. The Xerolyt solid polymer reference system allows an open annular junction to prevent fouling or contamination problems and ensure accurate measurements and low sensor maintenance.

PRODUCTS

2100 pH/ ORP Analyzer

- Detachable front panel and plug-in terminals for ease of installation
- All functions accessible through the keypad for increased ease of use
- Continuous sensor and transmitter diagnostics to monitor performance
- FM certification for Class I, Div 1 & 2 Environments and CSA General Purpose Approval
- 3 year warranty

Xerolyt® pH or ORP Electrode

- Patented Xerolyt solid polymer reference system maintains a stable potential for accurate and repeatable pH measurement and low maintenance
- Open junction eliminates reference clogging and extends sensor life
- High pressure resistance eliminates requirement for pressurizable housing
- Xerolyt solid polymer is particularly suitable for use in emulsions, suspensions, heavily contaminated or sulfide-containing media, and solutions with high concentration of suspended solids

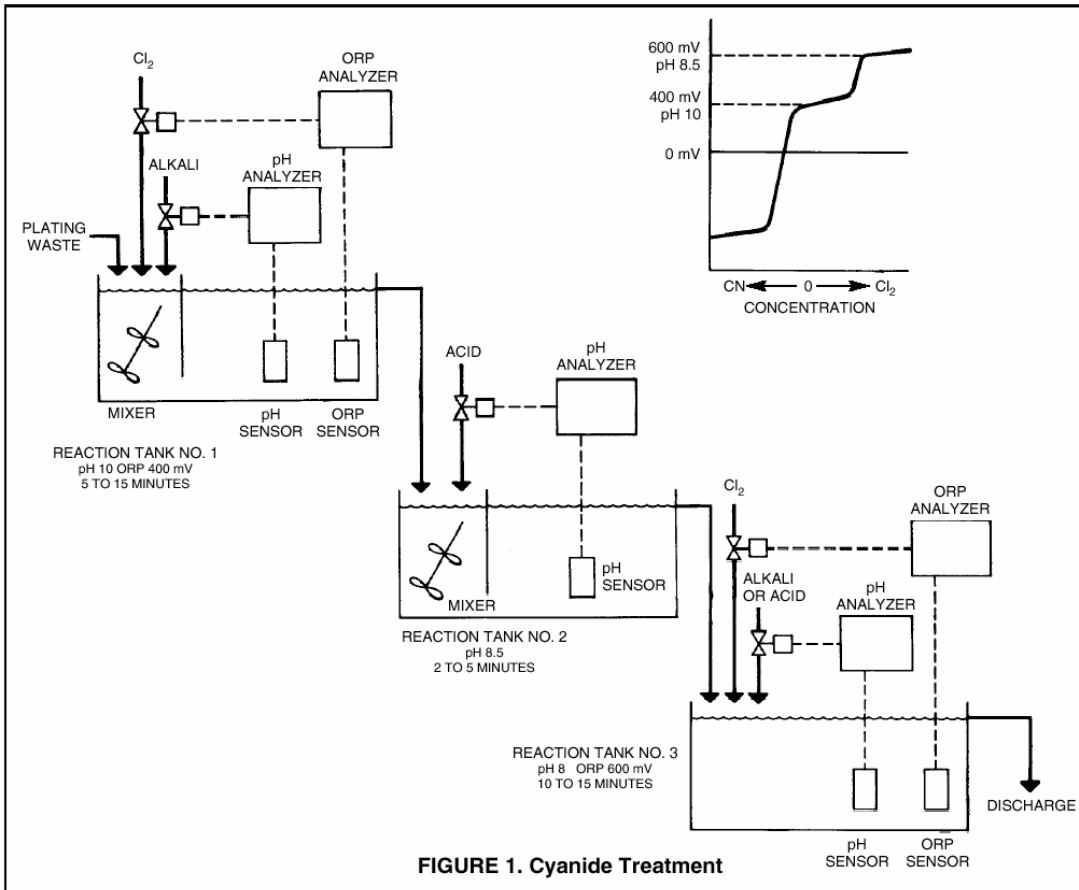

FIGURE 1. Cyanide Treatment

Ref: RA ADS 3300-01